



**CONFORMITY DECLARATION**  
Frame the QR code with your smartphone or tablet to view the conformity declaration.

**Technical data**

- Fluids: hot water, cold water, air
- Min. allowable temperature (Ts min): 5 °C
- Max. allowable temperature (Ts max): 110 °C
- Max. allowable pressure (Ps): 10 bar
- Open overpressure 20%
- Closure range 20%
- PED cat.: IV

**Materials**

- Body: brass UNI EN 12165 CW617N
- Membrane: EPDM
- Stem: copper
- Separator: brass UNI EN 12164 CW617N
- Gasket: vegetable fiber
- Spring: steel
- Spring presser: brass UNI EN 12164 CW617N
- Bonnet: brass UNI EN 12165 CW617N
- Knob: POM

**Description**

The Giacomini safety valves of the R140, R140M range are used to avoid overpressure on the heat generators of the heating system, domestic water system (protecting the hot water accumulation) and water systems (cold water drainage). The valves comply with Directive "PED" 2014/68/UE.

**Versions and product codes**

Series	Product code	Connections	Calibration pressure [bar]
R140	R140Y001	G 1/2" F x G 1/2" F	1,5
	R140Y002		2,5
	R140Y003		3
	R140Y005		3,5
	R140Y006		4
	R140Y007		4,5
	R140Y008		5
	R140Y009		6
	R140Y010		7
	R140Y011		8
	R140Y013	10	
	R140Y020	G 3/4" F x G 3/4" F	2
	R140Y021		1,5
	R140Y022		2,5
	R140Y023		3
	R140Y025		3,5
	R140Y026		4
	R140Y027		4,5
	R140Y028		5
	R140Y029		6
	R140Y031		8
	R140Y032	10	
	R140Y040	G 1" F x G 1" F	2
	R140Y042		2,5
	R140Y043		3
	R140Y045		3,5
	R140Y046		4
	R140Y047		4,5
	R140Y048		5
	R140Y049		6
	R140Y051		8
	R140Y052		10
R140Y062	G 1-1/4" F x G 1-1/4" F	2,5	
R140Y063		3	
R140Y065		3,5	
R140Y066		4	
R140Y067		4,5	
R140Y068		5	
R140Y068		5	
R140Y069		6	
R140M	R140MY003	G 1/2" M x G 1/2" F	3

**Operation**

The safety valves are used in hot water thermal systems with a closed expansion tank, to ensure that the pressure of the fluid in the heat generator does not exceed the project limits; when the thrust of the pressurised fluid triggers a return spring on the shutter, the valve discharges a specific amount of fluid to prevent the defined pressure level from being exceeded, and then re-closes within the permitted closure range. They can also be used to drain off cold water in water systems. They are factory-calibrated and the drainage pressure value cannot be altered.

**Installation**

Before installing any safety valve, the technical personnel in charge of the system must size it correctly, in accordance with the current regulations. The safety valves must be installed in the highest part of the heat generator, or on the delivery pipe, no more than 1m from the generator. They must be clearly visible and easy to check. The pipe connecting the safety valve to the generator must be free of any interception and with a diameter no less than that of the valve itself. The safety valve drainage must be clearly visible and channelled into a pipe with a diameter no less than that of the valve itself, using a funnel (R141 or R141C) if necessary.



**Warning.**  
The safety valves can be assembled vertically or horizontally, but not upside down (to prevent system impurities from settling); respect the flow direction indicated by the arrow on the body.

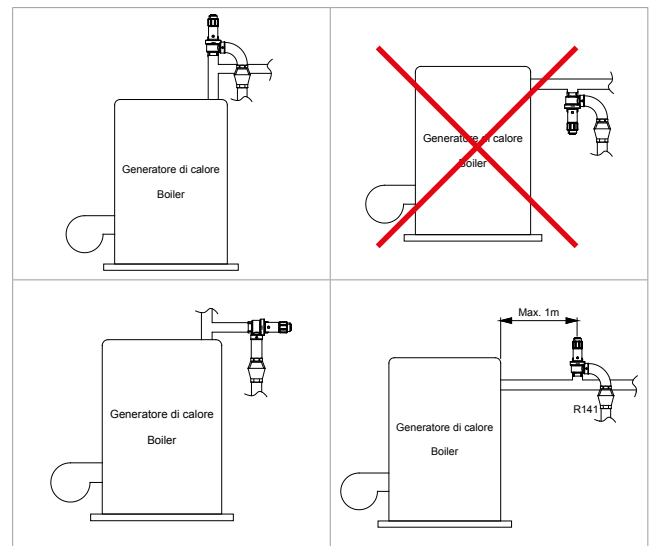

## Performance



The Giacomini R140, R140M valves comply with the "R" collection regarding the safety of devices containing hot pressurised liquids: *"In the case of heating systems for water destined for consumption, the expansion system that protects the container can be made with a vent valve (i.e. a valve with a counter-weight or spring, whose hole diameter - in mm - is no less than  $\sqrt{V/5}$  where V is the volume - in litres - of the heater, and anyway minimum 15 mm)."*

Product code	Connections	Orifice diameter [mm]	Net cross section [mm <sup>2</sup> ]	Outflow coefficient K	Calibration pressure [bar]	Nominal discharge press. [bar]	Closing pressure [bar]	Drainage capacity [kg/h]	Max. generator potential [kW]	Max. generator potential [kcal/h]				
R140Y001	G 1/2"F x G 1/2"F	16	200,96	0,112	1,5	1,8	1,2	44,66	25,9	22273				
R140Y002					2,5	3	2	57,66	33,4	28754				
R140Y003					3	3,6	2,4	63,16	36,6	31498				
R140Y005					3,5	4,2	2,8	68,22	39,6	34022				
R140Y006					4	4,8	3,2	72,93	42,3	36371				
R140Y007					4,5	5,4	3,6	77,35	44,9	38577				
R140Y008					5	6	4	81,54	47,3	40664				
R140Y009					6	7,2	4,8	89,32	51,8	44545				
R140Y010					7	8,4	5,6	96,48	56,0	48114				
R140Y011					8	9,6	6,4	103,14	59,8	51436				
R140Y013					10	12	8	115,31	66,9	57508				
R140Y020					G 3/4"F x G 3/4"F	20	314,00	0,122	2	2,4	1,6	89,68	52,0	44724
R140Y021									1,5	1,8	1,2	77,67	45,0	38732
R140Y022	2,5	3	2	100,27					58,2	50003				
R140Y023	3	3,6	2,4	109,84					63,7	54776				
R140Y025	3,5	4,2	2,8	118,64					68,8	59164				
R140Y026	4	4,8	3,2	126,83					73,6	63249				
R140Y027	4,5	5,4	3,6	134,52					78,0	67086				
R140Y028	5	6	4	141,80					82,2	70715				
R140Y029	6	7,2	4,8	155,33					90,1	77464				
R140Y031	8	9,6	6,4	179,36					104,0	89448				
R140Y032	10	12	8	200,53					116,3	100006				
R140Y040	G 1"F x G 1"F	24	452,16	0,086					2	2,4	1,6	90,06	52,2	44916
R140Y042									2,5	3	2	100,69	58,4	50217
R140Y043					3	3,6	2,4	110,31	64,0	55010				
R140Y045					3,5	4,2	2,8	119,14	69,1	59418				
R140Y046					4	4,8	3,2	127,37	73,9	63520				
R140Y047					4,5	5,4	3,6	135,10	78,4	67374				
R140Y048					5	6	4	142,40	82,6	71018				
R140Y049					6	7,2	4,8	156,00	90,5	77796				
R140Y051					8	9,6	6,4	180,13	104,5	89831				
R140Y052					10	12	8	201,39	116,8	100435				
R140Y062					G 1-1/4"F x G 1-1/4"F	31	754,385	0,057	2,5	3	2	111,35	64,6	55530
R140Y063									3	3,6	2,4	121,98	70,7	60830
R140Y065									3,5	4,2	2,8	131,75	76,4	65704
R140Y066	4	4,8	3,2	140,85					81,7	70241				
R140Y067	4,5	5,4	3,6	149,39					86,6	74502				
R140Y068	5	6	4	157,47					91,3	78532				
R140Y069	6	7,2	4,8	172,50					100,1	86027				
R140MY003	G 1/2"M x G 1/2"F	16	200,96	0,112	3	3,6	2,4	63,16	36,6	31498				

Data calculated in accordance with UNI EN ISO 4126-1. Maximum generator power calculated as the product of the drainage capacity multiplied by the fluid vaporisation heat, at ambient pressure W = 1,013 bar

**Accessories**

It is a good idea to channel the fluids drained by the safety valves with the aid of a funnel R141 or R141C (to be ordered separately).

Relief funnel R141	Relief funnel R141C	For safety valve with drainage of:
		
R141Y003	-	1/2"
R141Y014	R141CY004	3/4"
R141Y015	R141CY005	1"
R141Y016	R141CY006	1 1/4"



**Note.**  
The use of the R141 relief funnels (plus curved couplings R19 and R189 if necessary) prevents any spray from reaching the electric components.

**Maintenance**

The valve must be checked at least once a year, by increasing the system pressure to induce drainage. If this is not possible, you can rotate the knob and check the drainage visually. Any impurities that form on the housing can be removed by means of regular purging.

**Dimensions**

Series	Product code	Connections	Dimensions (A x B x C) [mm]	Suitable relief funnel
R140	R140Y001	G 1/2"F x G 1/2"F	48 x 84 x 38	R141Y003
	R140Y002			
	R140Y003			
	R140Y005			
	R140Y006			
	R140Y007			
	R140Y008			
	R140Y009			
	R140Y010			
	R140Y011			
	R140Y013	G 3/4"F x G 3/4"F	58 x 94 x 47	R141Y014 R141CY004
	R140Y020			
	R140Y021			
	R140Y022			
	R140Y023			
	R140Y025			
	R140Y026			
	R140Y027			
	R140Y028			
	R140Y029			
	R140Y031	G 1"F x G 1"F	69 x 146 x 55	R141Y015 R141CY005
	R140Y032			
	R140Y040			
	R140Y042			
	R140Y043			
	R140Y045			
	R140Y046			
	R140Y047			
	R140Y048			
R140Y049				
R140Y051	G 1-1/4"F x G 1-1/4"F	86 x 151 x 69	R141Y016 R141CY006	
R140Y052				
R140Y062				
R140Y063				
R140Y065				
R140Y066				
R140Y067				
R140Y068				
R140Y069				
R140M	R140MY003	G 1/2"M x G 1/2"F	48 x 102 x 38	R141Y003

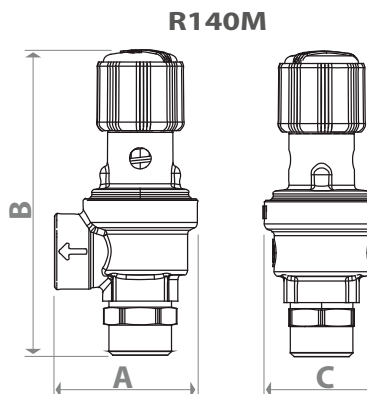
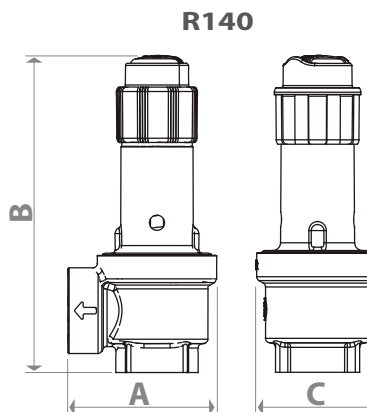



## Product specifications

### R140

Ordinary membrane safety valve. Female-female connections G 1/2"F, G 3/4"F, G 1"F, G 1-1/4"F. Fluids: hot water, cold water, air. Body: brass UNI EN 12165 CW617N. Membrane: EPDM. Stem: copper. Separator: brass UNI EN 12164 CW617N. Gasket: vegetable fiber. Spring: steel. Spring presser: brass UNI EN 12164 CW617N. Bonnet: brass UNI EN 12165 CW617N. Knob: POM. Min. allowable temperature (Ts min): 5 °C. Max. allowable temperature (Ts max): 110 °C. Max. allowable pressure (Ps): 10 bar. Open overpressure 20%. Closure range 20%. Compliance with Directive "PED" 2014/68/UE (cat.IV). Factory calibration: 1,5 - 2 - 2,5 - 3 - 3,5 - 4 - 4,5 - 5 - 6 - 7 - 8- 10 bar.

### R140M

Ordinary membrane safety valve. Male-female threaded connections of G 1/2"M x G 1/2" F. Fluids: hot water, cold water, air. Body: brass UNI EN 12165 CW617N. Membrane: EPDM. Stem: copper. Separator: brass UNI EN 12164 CW617N. Gasket: vegetable fiber. Spring: steel. Spring presser: brass UNI EN 12164 CW617N. Bonnet: brass UNI EN 12165 CW617N. Knob: POM. Min. allowable temperature (Ts min): 5 °C. Max. allowable temperature (Ts max): 110 °C. Max. allowable pressure (Ps): 10 bar. Open overpressure 20%. Closure range 20%. Compliance with Directive "PED" 2014/68/UE (cat.IV). Factory calibration: 3 bar.

## Additional information

For additional information please check the website [www.giacomini.com](http://www.giacomini.com) or contact the technical service: ☎ +39 0322 923372 📠 +39 0322 923255 ✉ [consulenza.prodotti@giacomini.com](mailto:consulenza.prodotti@giacomini.com)  
This pamphlet is merely for information purposes. Giacomini S.p.A. retains the right to make modifications for technical or commercial reasons, without prior notice, to the items described in this pamphlet. The information described in this technical pamphlet does not exempt the user from following carefully the existing regulations and norms on good workmanship.  
Giacomini S.p.A. Via per Alzo, 39 - 28017 San Maurizio d'Opaglio (NO) Italy